

# Ice Maker

## Instruction Manual

SKU: IM-FP





# Congratulations

Dear Customer:

Welcome to the Euhomy family. Thank you for purchasing one of our products.

Our goal is to provide you with superior service. If there is anything missing from or wrong with your order, or if you have any questions about using our ice maker, PLEASE contact us.

Email: [support@euhomy.com](mailto:support@euhomy.com).

Facebook: [@Euhomy.Official](https://www.facebook.com/Euhomy.Official)

The Euhomy team is available 24/7 to address your questions, comments, and concerns. Your satisfaction is our ultimate goal. We want to make everything right so you'll share your positive experience with other shoppers on Amazon.

If you experience any problems, please send an email to [support@euhomy.com](mailto:support@euhomy.com).

Our mission:

- \* To be the most trusted appliance brand.
- \* To create practical, compact appliances that better your life.

*Be sure to register at*  
**[www.euhomy.com/register](http://www.euhomy.com/register)**  
*for updates, warranty, and other relevant information.*

# I Q&A

## 1. How often do I need to clean my ice maker?

Depending on how frequently you use it, it is recommended that you clean it at least once a week. Failure to clean the machine will cause scale accumulation, which will eventually block the pump and cause the product to stop working properly.

## 2. How should I clean the machine?

It is recommended to use lemon water or weak acid vinegar for cleaning. Drain immediately after cleaning, and then clean it with pure water.

It is recommended to drain the water at least once every three days (pulling out the small hose on the right side of the water tank). Draining will not only ensure that the hardness of the water is not too high, but also ensure that impurities can be discharged well, and it is not easy to produce scale in the water tank.

## 3. Why is my ice cube cloudy?

It means that the water quality is turbid. It is recommended to use drinking water and distilled water. If your water quality problem is serious, it is recommended that you install a water filter kit.

## 4. Can I put milk and juice into the water tank to make ice cubes?

We recommend that you do not do that. Our research has found that the high concentration of milk and beverages can easily block the pump and reduce the life span of the pump. At the same time, the protein in milk is prone to calcification, which chemically reacts with the PU water pipe inside the machine, which easily breaks it, making the product unable to continue working.

## 5. Why does my ice cube melt easily?

Since the ice maker is not a refrigerator, it does not have a heat preservation function. The high ambient temperature in summer will accelerate the melting of ice cubes. You can close the lid of the machine to keep the internal temperature. Some customers also put electric fans on the side of the machine to blow away the hot air surrounding the device, thus solving the problem. Feel free to try it yourself. However, if you are not using ice cubes for a long time, we recommend removing them from the ice basket and storing them in the refrigerator.

## 6. Why is my ice so thick and difficult to fall from the ice tray? What should I do?

It may be that your ice making time is set for too long, or it may be that the temperature of your environment is very low. You can reduce the time to 0 or -6 by pressing the minus key on the touch panel.

## 7. Why does the ice cubes have a plastic smell?

The ice cube itself has no taste. If you feel there is a plastic smell, try to clean the inside of the machine with lemon water, then run a few cycles, and finally rinse with distilled water.

## 8. Why is there noise in the operation of my machine?

There is a faint sound when the machine is running. Closing the lid can reduce the noise. If the water pump makes a noise during use, it is recommended to turn off the machine first, and then turn on the machine after cleaning the filter in the water tank to observe whether or not the noise disappears.

## 9. Why is water leaking from my machine?

It may be that the PUA tube inside the machine fell off during transportation. You can remove the back cover of the machine and connect it by yourself. If you don't know how to operate, please contact the Euhomy team. We will give you a professional video to help you solve the problem.

## 10. Why is there water flowing but not making ice?

Please provide a video or picture and send it to us. The Euhomy team will assist you.



# Contents

Safety Precautions	02-03
Operation & Installation	03-07
Tips & Maintenance	08
Specifications	09
Warranty	10
Troubleshooting (support@euhomy.com)	11

# Safety Precautions

## IMPORTANT SAFETY TIPS

**When using electrical appliances, basic safety precautions should be followed to reduce the risk of fire, electric shock, and injury to persons or property. Read all instructions before using any appliance.**

- Do not operate this or any other appliance with a damaged cord.  
If the supply cord is damaged, it must be replaced by the manufacturer, its service agent, or a similarly qualified person in order to prevent a hazard.  
This ice maker must be positioned so that the plug is accessible. Connect to properly polarized outlets only. No other appliances should be plugged into the same outlet. Be sure that the plug is fully inserted into the receptacle.
- Do not run the power cord over carpeting or other heat insulators. Do not cover the cord. Keep the cord away from traffic areas. Do not submerge the cord or the appliance in water.  
We do not recommend the use of an extension cord, which may overheat and become a fire hazard. If you must use an extension cord, use No. 14 AWG minimum size, rated no less than 1875 W.
- Unplug the ice maker before cleaning, maintaining, or repairing it.
- Exercise caution and use reasonable supervision when the appliance is used near children.
- Do not use your ice maker outdoors. Place the ice maker out of direct sunlight. Be sure to leave at least 6 inches of space between the back of your unit and the wall. Keep a minimum distance of 6 inches on each side of your unit free.
- Do not try to make ice cubes with liquids other than water.
- Do not clean your ice maker with flammable fluids. The fumes can create a fire hazard or explosion.
- Do not tip over the ice maker or turn it upside down.
- If the ice maker is brought in from outside in a cold season or climate, give it a few hours to warm up to room temperature before plugging it in.

### **Risk of Fire or Explosion: Flammable Refrigerant Used!**

- Do not use mechanical devices to defrost the ice maker.
- Do not puncture the refrigerant tubing.
- Appliance is to be repaired only by trained service personnel.
- Consult the owner's guide before attempting to install or service this product. All safety precautions must be followed.
- Dispose of this appliance in accordance with federal or local regulations.
- Follow handling instructions carefully.
- The ice maker should be installed in accordance with the safety standard for refrigeration systems, ASHRAE 15.
- The ice maker shall not be installed in corridors of public buildings.
- If the unit needs maintenance or repairs, replace failed parts only with like parts. Service shall be done only by factory-authorized service personnel to minimize the risk of ignition due to incorrect parts or improper service.

# I Safety Precautions



## Note:

The wires in this electrical cord are color-coded as follows:  
Green or Green with a strip

COLOR	WIRING
Yellow	Grounding
White	Neutral
Black	Live

To prevent a hazard resulting from instability of the appliance, it must be placed on a flat, even surface.

# Operation & Installation

## ASSEMBLY AND PARTS

### 1. Control panel

#### A. TIMER/CLEAN button

- Quickly press this button once to enter the timer settings.
- Press and hold the button for more than 5 seconds to enter the cleaning program.

#### B. ON/OFF button

- Press this button to turn the unit on or off.
- When the unit is making ice cubes, press this button for more than 5 seconds to force the ice harvesting process.

#### C. LCD display

1. Numerical display shows <M> for ice-making countdown or <°F> for ambient temperature.
2. Ice cube status indicator: When the symbol is rotating, the unit is making ice cubes. When the symbol is flashing, the unit is harvesting ice.
3. Automatic self-cleaning indicator
4. ON/OFF indicator
5. Error code indicator: E1 = ambient temperature sensor fault.  
E2 = water temperature sensor fault.  
E = ice-making glitch or refrigerant leakage.

#### 6. Water Low warning indicator

#### 7. Ice Full indicator

#### 8. Time setting indicator: <H> = timer ON/OFF; <M> = ice-making cycle length.

#### D. Time decrease button for ice-making cycle and timer.

#### E. Time increase button for ice-making cycle and timer.

### 2. Ice basket

### 3. Evaporator

### 4. Water separator pipe

### 5. Unit top cover

### 6. Water tank cover

### 7. Support seat for water bottle (on certain units only)

### 8. Hot air vent

### 9. Water drainage port

### 10. Ice scoop

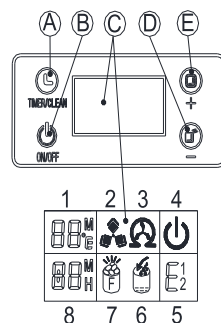
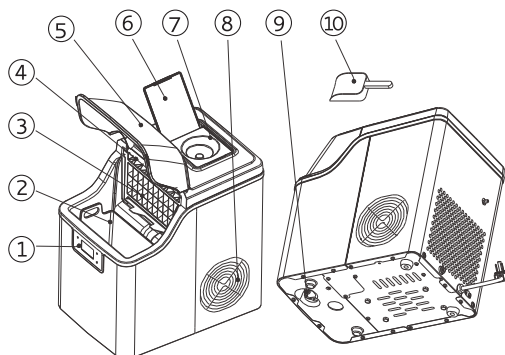

# Operation & Installation

## UNPACKING YOUR ICE MAKER

- Remove the exterior and interior packaging. Check that the ice basket and ice scoop are included. If any parts are missing, please contact Customer Service.
- Clean the interior with a soft cloth dampened with plain lukewarm water. Take out the ice basket and scoop, and wash them in warm, soapy water. Then rinse, dry, and re-place the basket and scoop.
- Find a location for your ice maker that is out of direct sunlight and away from other sources of heat (e.g., a stove, furnace, or radiator).
- Place the ice maker on a flat, level surface.
- Be sure that there is at least 6 inches of space between the back and sides of your ice maker and any walls.
- After unpacking or moving the ice maker, allow 1 hour for the refrigerant fluid to settle before plugging in the appliance.
- The appliance must be positioned so that the plug is accessible.



**Note:** Fill with potable water only.

## CONNECTING YOUR ICE MAKER

Improper use of the grounded plug can increase the risk of electrical shock. If the power cord is damaged, please call Customer Service.

- This unit should be properly grounded for your safety. The power cord of this appliance is equipped with a three-prong plug, which mates with standard three-prong wall outlets to minimize the possibility of electric shock.
- Plug your appliance into an exclusive, professionally installed, grounded wall outlet. Do not, under any circumstances, cut or remove the third (ground) prong from the power cord. Any questions concerning power and/or grounding should be directed to a certified electrician.
- This appliance requires a standard 110–120V, 60Hz electrical outlet with three-prong ground.

# Operation & Installation

## OPERATION PANEL AND DISPLAY AREA

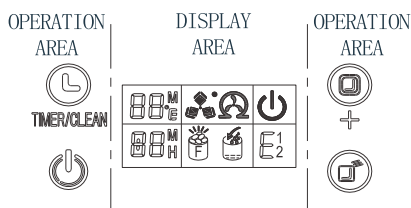

1. Remove the water tank cover and pour potable water into the tank. Be sure to keep the water level

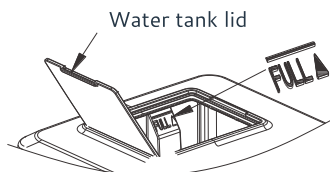

1. below the maximum level (see FULL mark in the image below).

Warning: Do not pour water into the internal water tank located underneath the ice basket. This tank is not sufficient for proper ice-making.

2. How to turn on the unit: Plug in the unit. The electric power symbol <⏻> will start to flash. The current ambient temperature will show at the top left corner of the display window. Press the ON/OFF button to start the unit. First, water will flow into the water tank to the standard water level. Then, the compressor will start running to make ice cubes. At the same time, the power symbol <⏻> will change to steady, the ice cube symbol <❄️> will rotate, and the ambient temperature display will disappear. After some minutes of ice-making duration, flashing digits will display in the ambient temperature display area. For example, if you see "10M" flashing, it means that the ice-making process will take 10 minutes to complete.

3. When the <❄️> symbol flashes, water will flow from the top water tank to the bottom water tank through the solenoid valve and the <🚰> symbol will be on. When the bottom water tank is full, the <🚰> symbol will turn off and the next ice-making cycle will start again. When there is no water in the water tank, the <🚰> symbol will stay on. Turn off the unit and fill the tank with water again. Then restart the unit to make ice cubes. Or add water directly and wait 20 minutes; the unit will restart automatically.

**Note:** The ice-making cycle lasts about 13 to 25 minutes, depending on the ambient temperature. And depending on the initial water temperature, the first ice-making cycle will be a little longer. In an extremely hot environment, ice-making time may vary but will not exceed 35 minutes.

If you think the ice cubes are not substantial enough, you can increase the cycle time. Press the <+> or <-> to adjust the ice-making lead time in 1-minute increments (6 minutes maximum) at the start of the next cycle.

# Operation & Installation

4. When the Ice Full indicator  is on, the unit will stop running. Take out the ice cubes and the unit will start working again.

While the ice maker is running, press and hold the <ON/OFF> button for at least 5 seconds to force ice harvesting. Press the <ON/OFF> button once to turn off the unit.

There is a timer setting function on the machine. When the machine is working, you can set the shutdown time at regular intervals. The appointment time would be invalid after shutdown. When the machine is turned off you can make an appointment to turn on the machine.

Press the <TIMER> button and the display will show <1H>. Press <+> and <-> to set the time. The "H" will flash while you are adjusting the setting. After 5 seconds of inactivity, the "H" will stay on and your timer setting will be saved.

5. Water drainage: Remove the water drainage cap the bottom of unit. Then drain out the water. It is suggested to change the water every 24 hours and clean the unit every 3 days.

## Automatic self-cleaning program

TIMER/CLEAN"button on control panel for more than 5 seconds, to enter the self-Cleaning program need 20minutes.the symbol  rotate on display screens, time count down area display 20M.

### Canceling the self-cleaning program:

It takes about 20 minutes to complete one self-cleaning cycle. When the cycle ends, the system will turn off automatically. You can also press the ON/OFF button to force stop the self-cleaning cycle.



## Warning:

A. Be sure the water tank, water filter, and water separator pipe are not clogged. If they are, clean them before trying to make more ice.

B. The water temperature will affect the ice-making capacity. The cooler the water, the more ice cubes produced.

C. The ambient temperature will affect the ice-making capacity. The cooler the ambient temperature, the more ice cubes produced.

D. Always use good-quality water to help the pump work at optimal efficiency. Bad-quality water will cause the pump to make noise but will not keep the unit from working.

E. If you turn off the unit, the compressor will restart after 3 minutes.

# I Tips & Maintenance

## CLEANING AND MAINTAINING YOUR ICE MAKER

**Before using your ice maker, it is strongly recommended to clean it thoroughly.**

- Take out the ice basket.
- Clean the interior with diluted detergent, warm water, and a soft cloth.
- Rinse the interior with clean water. Drain out the water through the drainage port by removing the drain cap on the back and taking out the silicone plug.
- The outside of the ice maker should be cleaned regularly with a mild detergent solution and warm water.
- Dry the interior and exterior with a soft cloth.
- When the machine will not be used for a long time, open the drain cap to drain water completely out of the water tank.
- After using your ice maker for about 3 days, we suggest that you clean the unit. The water separator pipe and water filters in particular must be cleaned periodically.
- If you don't hear liquid flowing while the compressor and water pump are running, the water separator pipe may be clogged. Please turn off the unit. Then remove this pipe down and clean it. Clean each hole along the pipe wall, as shown in the following picture. After cleaning, reinstall the water separator pipe in its original orientation, making sure that the right end of the pipe is connected to the silicone pipe well.

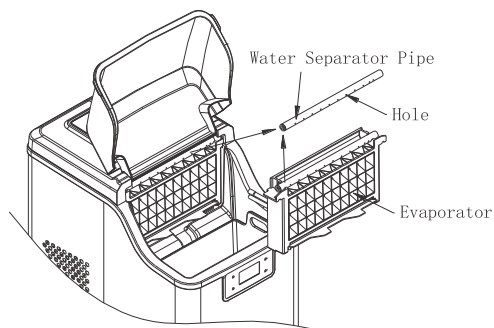

- Clean both water tanks with diluted detergent, warm water, and a soft cloth. Use clean water to rinse the inside of the unit. Drain out the water through the drainage port by removing the drain cap and plug on the back. Regular cleaning will keep the unit and your ice cubes sanitary, and also help the unit work normally.
- How to completely drain the internal tank and large water tank: The water in the large water tank is kept out of the drainage port by the water valve. If you want to drain out all the water, please plug on the unit but do not start it. Then remove the drainage port cap at the back. Wait a few minutes and then all of the water will flow out.



# I Specifications

## TECHNICAL PARAMETERS

MODEL	IM-FP
Protection Type	I
Climate Type	SN/N/ST
Power	115V/60Hz
Ice-Making Current	2.2A
Ice-Harvest Current	2.5A
Refrigerant	R290/32g
Net Weight	10kg
Vesicant	C <sub>5</sub> H <sub>10</sub>
Enclosure	Plastic

## CIRCUIT DIAGRAM

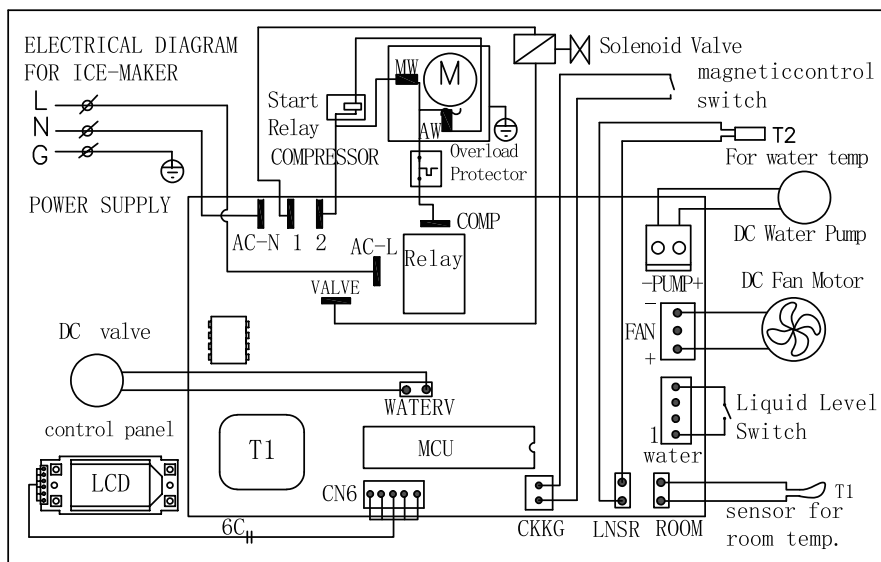

# Warranty

Euhomy offers a limited 1-year warranty ("warranty period") on all of our products purchased new and unused from Euhomy company, with an original proof of purchase and where a defect has arisen, wholly or substantially, as a result of faulty manufacture, parts or workmanship during the warranty period. The warranty does not apply where damage is caused by other factors, including without limitation:

- (a) normal wear and tear;
- (b) abuse, mishandling, accident, or failure to follow operating instructions;
- (c) exposure to liquid or infiltration of foreign particles;
- (d) servicing or modifications of the product other than by Euhomy;
- (e) commercial or non-household use.

The Euhomy warranty covers all costs related to restoring the proven defective product through repair or replacement of any defective part and necessary labor so that it conforms to its original specifications. A replacement product may be provided instead of repairing a defective product. Euhomy's exclusive obligation under this warranty is limited to such repair or replacement. A receipt indicating the purchase date is required for any claim, so please keep all receipts in a safe place. Although greatly appreciated, the product registration is not required to activate any warranty and product registration does not eliminate the need for the original proof of purchase. The warranty becomes void if attempts at repair are made by non-authorized third parties and/or if spare parts, other than those provided by Euhomy, are used.

You may also arrange for service after the warranty expires at an additional cost. These are our general terms for warranty service, but we always urge our customers to reach out to us with any issue, regardless of warranty terms. If you have an issue with a Euhomy product, please contact us (support@euhomy.com.), and we will do our best to resolve it for you.

## Option 1



1. Search for "QR Code" on Facebook.
2. Scan the attached QR Code.
3. Become a member of the group.
4. Activate your warranty in the pinned post.



## Option 2

1. Open your phone build-in Camera.
2. Point it to the attached QR Code. Make sure you can see all four corners of the QR code in the camera.
3. Tap the pop-up banner and go to the Active Your Warranty link.
4. Become a member of the group, and your warranty is now active



Problem	Possible Cause	Solution
<  > is displayed	Lack of water	Turn off the unit. Add water to the <FULL> mark. Restart the unit.
<  > code is displayed	Too much ice in the basket	Remove ice cubes from the basket.
Water tank contains water but <  > is displayed	Faulty inlet solenoid valve	Contact a technical service person for repair.
< E > code is displayed	The ice making system damage	The ice making system damage
	Too much water in the ice basket	Drain out the water below the ice basket, and then turn on the unit.
< E1 > code is displayed	Faulty ambient temperature sensor	The unit will still work, but the sensor should be replaced promptly.
< E2 > code is displayed	Faulty refrigerating tube sensor	The unit will still work, but the sensor should be replaced promptly.
< F > code is displayed	The ice full plate blocked	Take out the ice cube under the ice full plate, make sure the ice full plate can roll smoothly. Or wait 2-4 hours until the ice cube melts and the ice full plate rolls back automatically.
No water in the water separator pipe	Blocked openings	Use a slim wire to prick each opening so water can flow through easily.
	Clogged water filter	Clean the water filter.
Thick or large ice cubes cannot drop into basket	Ice-making cycle too long	Press <-> to shorten the ice-making cycle.
Thin or small ice cubes	Ambient temperature too high	Move the unit to a cooler place.
	Water temperature too high	The water temperature should be no more than 25 °C (77 °F).
	Ice-making cycle too short	Press <+> to lengthen the ice-making cycle.
Unit runs but does not make ice	Ambient temperature or water temperature too high	Move the unit to an area where the ambient temperature is <30 °C (<86 °F). Refill the tank with cool water.
	Refrigerant system leakage	Contact a technical service person for repair.
	Refrigerant system blockage	Contact a technical service person for repair.

# EUHOMY

# Live the *cool life*



Email: [support@euhomy.com](mailto:support@euhomy.com)



Facebook: [@Euhomy.Official](https://www.facebook.com/Euhomy.Official)