

Under counter Ice Maker

SKU: CIM010-80SI-USEH

MODEL: HBZB-36F

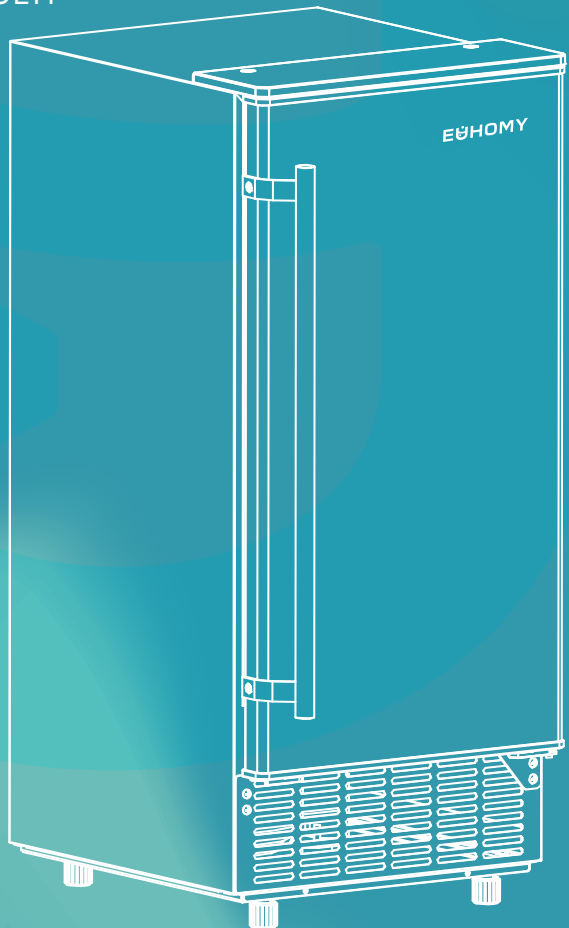

Congratulations

Dear Customer:

Welcome to the Euhomy family. Thank you for purchasing one of our products.

Our goal is to provide you with superior service. If there is anything missing from or wrong with your order, or if you have any questions about using our ice maker, PLEASE contact us.

Email: support@euhomy.com

Facebook: [@Euhomy.Official](https://www.facebook.com/Euhomy.Official)

The Euhomy team is available 24/7 to address your questions, comments, and concerns. Your satisfaction is our ultimate goal. We want to make everything right so you'll share your positive experience with other shoppers on Amazon.

If you experience any problems, please send an email to support@euhomy.com.

Our mission:

* To be the most trusted appliance brand.

* To create practical, compact appliances that better your life.

Be sure to register at
www.euhomy.com/register
for updates, warranty, and other relevant information.

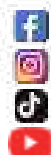

EuhomyOfficial

euhomyofficial

euhomy_us

euhomy

EUHOMY

Live the *cool life*

I Q&A

1. How often do I need to clean my ice maker?

Depending on how frequently you use it, it is recommended that you clean it at least once a week. Failure to clean the machine will cause scale accumulation, which will eventually block the pump and cause the product to stop working properly.

2. How should I clean the machine?

It is recommended to use lemon water or weak acid vinegar for cleaning. Drain immediately after cleaning, and then clean it with pure water.

It is recommended to drain the water at least once every three days (pulling out the small hose on the right side of the water tank). Draining will not only ensure that the hardness of the water is not too high, but also ensure that impurities can be discharged well, and it is not easy to produce scale in the water tank.

3. Why is my ice cube cloudy?

It means that the water quality is turbid. It is recommended to use drinking water and distilled water. If your water quality problem is serious, it is recommended that you install a water filter kit.

4. Can I put milk and juice into the water tank to make ice cubes?

We recommend that you do not do that. Our research has found that the high concentration of milk and beverages can easily block the pump and reduce the life span of the pump. At the same time, the protein in milk is prone to calcification, which chemically reacts with the PU water pipe inside the machine, which easily breaks it, making the product unable to continue working.

5. Why does my ice cube melt easily?

Since the ice maker is not a refrigerator, it does not have a heat preservation function. The high ambient temperature in summer will accelerate the melting of ice cubes. You can close the lid of the machine to keep the internal temperature. Some customers also put electric fans on the side of the machine to blow away the hot air surrounding the device, thus solving the problem. Feel free to try it yourself. However, if you are not using ice cubes for a long time, we recommend removing them from the ice basket and storing them in the refrigerator.

6. Why is my ice so thick and difficult to fall from the ice tray? What should I do?

It may be that your ice making time is set for too long, or it may be that the temperature of your environment is very low. You can reduce the time to 0 or -6 by pressing the minus key on the touch panel.

7. Why does the ice cubes have a plastic smell?

The ice cube itself has no taste. If you feel there is a plastic smell, try to clean the inside of the machine with lemon water, then run a few cycles, and finally rinse with distilled water.

8. Why is there noise in the operation of my machine?

There is a faint sound when the machine is running. Closing the lid can reduce the noise. If the water pump makes a noise during use, it is recommended to turn off the machine first, and then turn on the machine after cleaning the filter in the water tank to observe whether or not the noise disappears.

9. Why is water leaking from my machine?

It may be that the PUA tube inside the machine fell off during transportation. You can remove the back cover of the machine and connect it by yourself. If you don't know how to operate, please contact the Euhomy team. We will give you a professional video to help you solve the problem.

10. Why is there water flowing but not making ice?

Please provide a video or picture and send it to us. The Euhomy team will assist you.

Contents

Important Safety Information	2-3
Specifications	4
General Information	5-8
Operation Procedures	9-16
Wiring Diagram	17-18
Cleaning And Maintenance	19-22
Troubleshooting	23
Error Indicator	24
Warranty	25

Important Safety Information

When using electrical appliances, basic safety precautions should be followed to reduce the risk of fire, electric shock, and injury to persons or property. Read all instructions before using any appliance.

- Use this appliance only for its intended purpose as described in this owner's manual. This ice maker must be properly installed in accordance with the installation instructions before it is used.
- This unit must be positioned so that the plug is accessible. Do not run the cord over carpeting or other heat insulators. Do not cover cord or set anything on top of it. Keep cord away from traffic areas, and do not submerge in water. No other appliance should be plugged into the same outlet, and be sure that the plug is fully inserted into the receptacle.
- We do not recommend the use of extension cord as it may overheat and cause a risk of fire. If you must use an extension cord, use No.14AWG minimum size and rated no less than 1875 watts.
- If the supply cord is damaged, it must be replaced by the manufacturer or its service agent or a similarly qualified person in order to avoid a hazard.
- Disconnect the mains plug from the supply socket when not in use for a long time, where supply connection is via mains plug.
- Remove power plug or disconnect from the mains before cleaning or servicing the appliance.

Note:

If for any reason this product requires service, we strongly recommend that a certified technician perform the service.

- Never unplug your unit by pulling on the power cord. Always grasp the plug firmly and pull straight out from the outlet.
- Do not use your unit outdoors. Keep the unit away from direct sunlight and make sure that there is at least 6 inches of space between the back of your unit and wall and keep the front free. Keep ventilation opening in the appliance enclosure or in the built-in structure, clear from obstruction.
- Do not tip over the unit which will cause abnormal noise and make the ice cube size abnormal. It may cause water leakage from the unit.
- If the unit is brought in from outside in the winter season, give it a few hours to warm up to room temperature before plugging it in.
- Do not use other liquids to make the ice cubes other than water.
- Do not clean your ice maker with flammable fluids. The fumes can create a fire hazard or explosion.
- **WARNING:** This appliance must be earthed. Use the proper power source according to the nameplate.
- **WARNING:** Keep ventilation openings, in the appliance enclosure or in the built-in structure, clear of obstruction.
- **WARNING:** Do not damage the refrigerant circuit.
- **WARNING:** This appliance is not intended for use by persons (including children) with reduced physical, sensory or mental capabilities, or lack of experience and knowledge, unless they have been given supervision or instruction concerning use of the appliance by a person responsible for their safety

Important Safety Information

- **WARNING:** Children should be supervised to ensure that they do not play with the appliance.
- **WARNING:** This appliance must be earthed and use the 110–120V/60Hz earthed power supply.
- **WARNING:** Do not store explosive substances such as aerosol cans with a flammable propellant in this appliance.
- **DANGER – Risk of Fire or Explosion. Flammable Refrigerant Used. Do Not Use Mechanical Devices to Defrost Ice Maker. Do Not Puncture Refrigerant Tubing.**
-  **DANGER – Risk of Fire Or Explosion. Flammable Refrigerant Used. To Be Repaired Only by Trained Service Personnel. Do Not Puncture Refrigerant Tubing.**
- **CAUTION – Risk of Fire Or Explosion. Flammable Refrigerant Used. Consult Repair Manual/Owner's Guide Before Attempting to Install or Service This Product. All Safety Precautions Must Be Followed.**
- **CAUTION – Risk of Fire Or Explosion. Dispose of Property In Accordance With Federal Or Local Regulations. Flammable Refrigerant Used.**
- **CAUTION – Risk of Fire Or Explosion Due To Puncture Of Refrigerant Tubing; Follow Handling Instructions Carefully. Flammable Refrigerant Used.**
- The ice maker should be installed in accordance with the safety standard for Refrigeration Systems, ASHRAE15. The ice maker shall not be installed in corridors or hallways of public buildings.
- If the unit is with problem need to be maintained, that replacing with like components and that servicing shall be done by factory authorized service personnel, so as to minimize the risk of possible ignition due to incorrect parts or improper service.
- **WARNING:** Keep ventilation openings, in the appliance enclosure or in the built-in structure, clear of obstruction.
- **WARNING:** This appliance is intended to be used in household and similar applications such as:
E.g. staff kitchen areas in shops, offices and other working environments;
E.g. farm houses and by clients in hotels, motels and other residential type environments;
E.g. bed and breakfast type environments;
E.g. catering and similar non-retail applications.



IMPORTANT:

The wires in this mains lead are colored in accordance with the following code:

Green or Green with a yellow strip:	Grounding
White:	Neutral
Black:	Live

- To avoid a hazard due to instability of the appliance, it must be placed at an even or flat surface.

I Specifications

DIMENSIONS/ CONNECTIONS

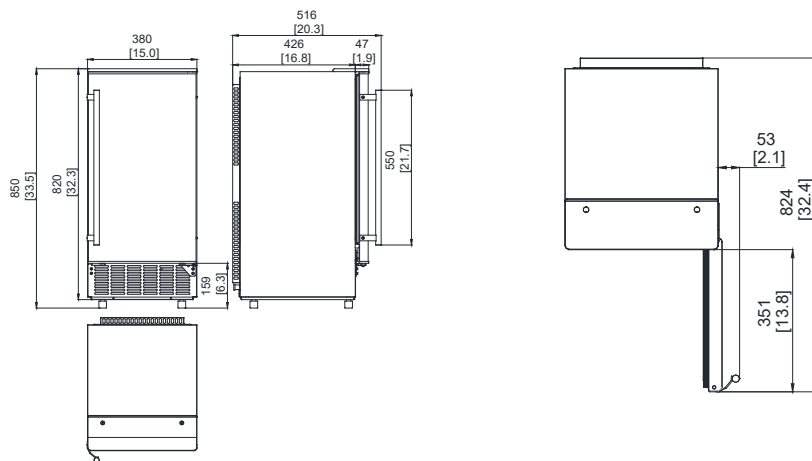

Rating

MODEL	HBZB-36F
POWER SUPPLY VOLTAGE	1Phase, 115V/60Hz
CLIMATE CLASS	10-40°C
ELECTRICAL PROTECTION CLASS	I
ICE MAKING RATING (Amps)	2.6Amp
ICE HARVEST RATING (Amps)	3.0Amp
ICE MAKING CAPACITY(KG/24H)	36kg/24Hour *
REFRIGERANT CHARGE	R290 2.65oz./75g
NET WEIGHT(lbs.)	52.5 lbs.
VEVICANT	C5H10
UNIT DIMENSIONS(W X D X H) (Inch)	14.96x18.47x33.9
MAX ICE STORAGE CAPACITY(lbs.)	24lbs
ACCESSORIES	SHOVEL, INSTALLATION KITS, HANDLE
CONNECTION	POWER CORD 18AWG WATER SUPPLY----6.35mm Diameter DRAIN Ø16 SYLPHON BELLOWSS(REAR)
RUNNING CONDITIONS	ROOM TEMP 50-110 Fahrenheit WATER SUPPLY TEMP 41-95 Fahrenheit WATER SUPPLY PRESSURE 0.04-0.6 MPa

NOTE*: TESTED AT 70 Fahrenheit ROOM TEMPERATURE AND 50 Fahrenheit WATER TEMPERATURE.

General Information

1. Main unit construction

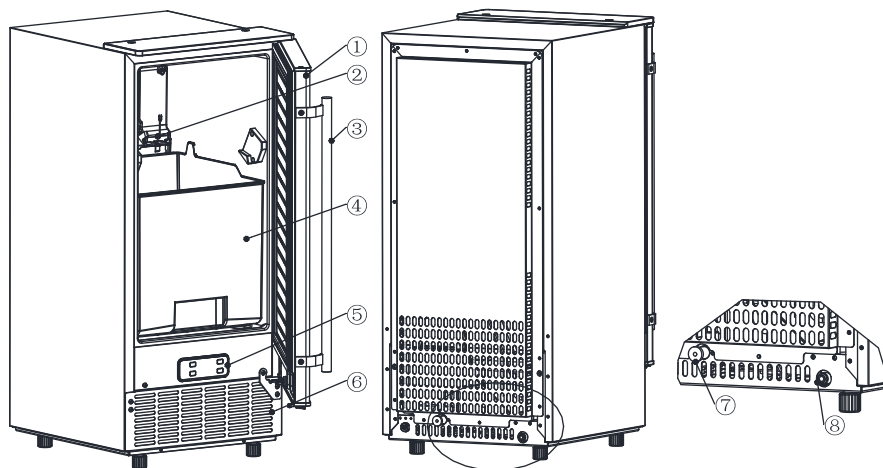

1. Door

2. Ice-making & its water tank assembly: Including ice-making evaporator, water tank, water pump and some detecting parts

3. Handle

4. Ice tank

5. Operation panel

6. Air outlet: Must keep the air circulate smoothly, hot air will blow out when unit running.

7. Water draining port: Normal plugged with the cap. When you need to drain the water, unplug the cap and connect the white drain pipe.

8. Water inlet port for water supply: Use to connect the water supply pipe.

Accessory: 2 meters long water drain pipe water and quick connector of the water faucet $\varnothing 6.35\text{mm}$ diameter and white color water supply pipe (3 meters long).

2. Ice-making assembly

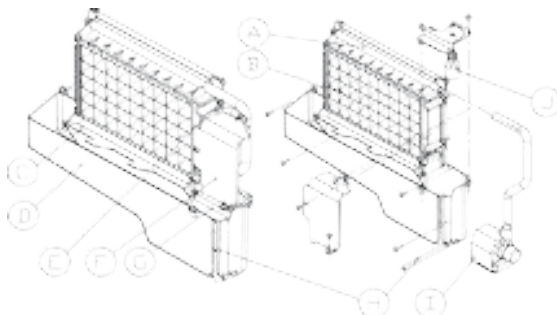

General Information

- A. Water dividing pipe: with nine little holes, water will flow out from these little holes. If no water flows out, can be disassembled and cleaned.
- B. Evaporator (ice-making module)
- C. Ice full detecting board: Use to detect the inner cabinet is full of ice or not, and to check the the ice-harvest process is over or not.
- D. Water tank
- E. Water supplying pipe
- F. Cover board on the right side of the evaporator
- G. Water level switch installing plate
- H. Water drain pipe of the water tank: when ice making, this pipe should be clamped in the slot of the water tank wall; And when draining, this pipe should be pulled out.
- I. Water pump
- J. Water level detecting switch

3. Operation panel

A. "TIMER CLEAN" button:

Quickly press this button once, to enter the timer setting program; And press this button for more than 5 seconds, to enter the cleaning program.

B. "ON/OFF" button:

When the unit is off, press this button to turn on the unit; and during the Self-cleaning program, or normal ice making state, press this button to turn off the unit at once; and also if the unit is set with the timer, press this button to cancel the timer setting. When the unit is making the ice cubes, press this button for more than 5 seconds, the unit will switch to ice harvest process by force.

C. LCD display window

1. Environmental temperature display and ice making time countdown display. Display ice-making time countdown with M as the unit display, and display environmental temperature with F as the unit display.

2. Making ice and de-ice symbol display, the machine is making ice when the symbol rotates, and the machine is de-ice when the symbol flash.

3. Automatic self-cleaning symbol display

4. ON/OFF symbol display

5. Error code display: E1 means the environmental temperature sensor is damaged.
E2 means ice making anomaly or the refrigerant leaked.

6. Water flow in and water shortage display, the arrow flashing indicates that the water is in the machine, the whole symbol is bright to indicate that the machine is short of water.

7. Ice full alarm, the machine will make ice again when you have taken out the ice.

8. Setting display: display timing switch machine with the H as unit display; display ice making time setting with M as unit display.

D&E. "+" / "-" button:

Use this to adjust the ice-making process duration period, the default setting is zero, 1 minute adding or decreasing per each pressing of "+" or "-" button.

Also to adjust the delay time of the timer, the default setting is zero, 1 hour adding or decreasing per each pressing of "+" or "-" button.

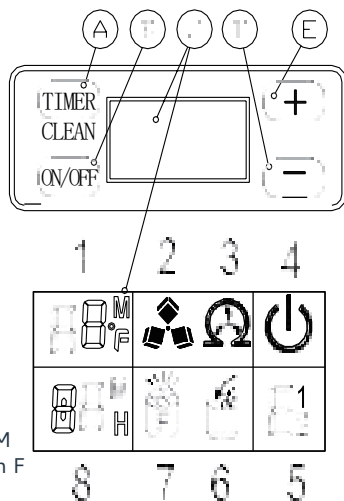

General Information

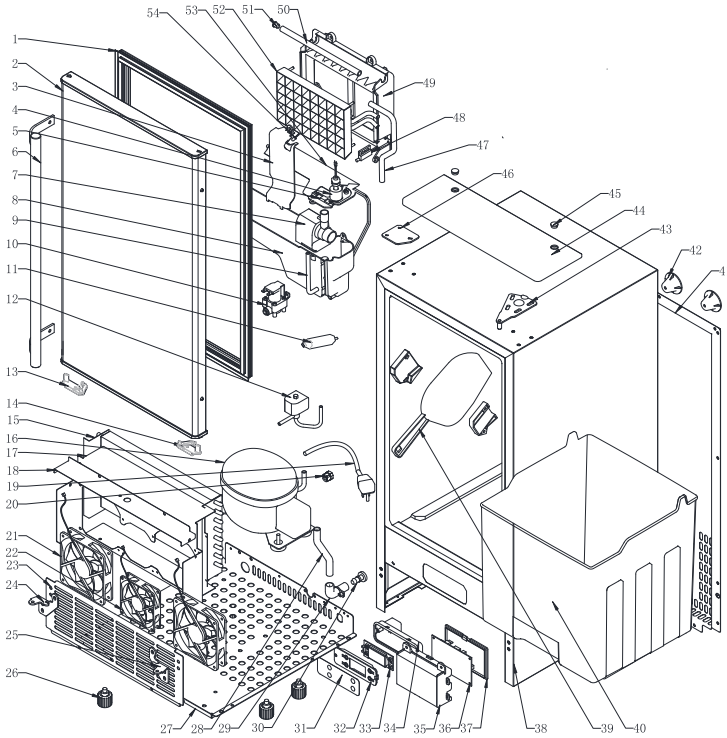

No.	Part Name	Specifications	Qty
1	Door seal	PVC	1
2	Door	SUS & Foams	1
3	Water tank side cover	ABS White	1
4	Float switch	Electrical part DC5V	1
5	Water tank cover	ABS White	1
6	Handle	SUS	1
7	Pump	Electrical part AC115V	1
8	Water Tank	ABS White	1
9	Drain tube for water tank	Silicone tube, FDA	1
10	Water inlet solenoid	Electrical part DC12V	1
11	Filter Dryer	Copper and dryer	1
12	Solenoid valve for ice release	Electrical part AC115V	1
13	Left fix piece	POM	1 (accessory)
14	Right fix piece	POM	1
15	Condenser	Copper and aluminum	1
16	Compressor & accessory	Electrical part AC115V	1
17	Fan fix plate	Zinc-Plate sheet $\delta=0.8$	1

General Information

18	Fan fix cover plate	Zinc-Plate sheet $\delta=0.6$	1
19	Plug + Power cord	Electrical part AC115V	1
20	Strain relief bushing	PP black	1
21	Fan	Electrical part DC12V 120mm	2
22	Fan	Electrical part DC12V 90mm	1
23	Air outlet panel	SUS430 $\delta=0.8$	1
24	Left bottom hinge	SPCC $\delta=2.5$ mm Chrome Plated	1 (accessory)
25	Right bottom hinge	SPCC $\delta=2.5$ mm Chrome Plated	1
26	Adjusted foot	M8*30mm	4
27	Bottom plate	Zinc-Plate sheet $\delta=1.2$	1
28	Drain tube on liner	Silicone tube, FDA	1
29	Water drainage port	ABS Gray, FDA	1
30	Water drainage cap	Rubber Black	1
31	Operation panel paper	PET, thickness 0.25mm	1
32	Operation panel PCB fix board	ABS Black	1
33	Operation panel PCB	Electrical part DC5V	1
34	Operation panel PCB box	ABS Black	1
35	Main PCB box	ABS 5V Black	1
36	Main PCB	Electrical part AC115V	1
37	Main PCB cover	ABS 5V Black	1
38	Foaming cabinet	Sheet metal +foams	1
39	Ice scoop	ABS White	1
40	Ice basket	PP White	1
41	Back-cover plate	Zinc-Plate sheet $\delta=0.6$	1
42	Back support column	PP black	4
43	Top hinge	SPCC $\delta=2.5$ mm Zinc-plated	1
44	Top cover	ABS Black	1
45	Screw hole cover	ABS Black	1
46	Fix plate	SPCC $\delta=2.5$ mm Zinc-plated	1
47	Water outlet tube form pump	Silicone tube, FDA	1
48	Magnet switch	Electrical part DC5V	1
49	Evaporator frame	ABS White	1
50	Water dividing pipe, eight holes	ABS White	1
51	Cap of the water dividing pipe	Silicone, FDA	1
52	Evaporator	Copper Nickle plated	1
53	Ice full detecting plate	ABS White	1
54	LED light	Electrical part DC5V white light	1

Operation Procedures

UNPACKING YOUR ICE MAKER

1. Remove the exterior and interior packaging. Check if all the accessories are inside or not including the instruction manual, ice scoop, white water inlet pipe, the water draining pipe, the quick connector (connecting a 1/4-inch connector with a 1/2-inch one) etc. If any parts are missing, please contact our customer service.
2. Remove the tapes for fixing the door and inner cabinet, ice scoop etc. Roughly clean the inner cabinet & ice scoop with a wet cloth.
3. Put the ice maker on a level & flat floor, without direct sunlight and other sources of heat (i.e.: stove, furnace, radiator). Make sure that there is at least a 50cm gap between the air outlet and the obstacles, and at least 5 cm between the wall.
4. Allow 4 hours for the refrigerant fluid to settle before plugging the ice maker in, as the unit may have fallen upside down during shipping or transportation.
5. The appliance must be positioned so that the plug is accessible.

WARNING: connect to potable water supply only. Only use drinking water.

Door reversing (Optional)

If you want the refrigerator door to open from the opposite side, you can reverse the door swing.

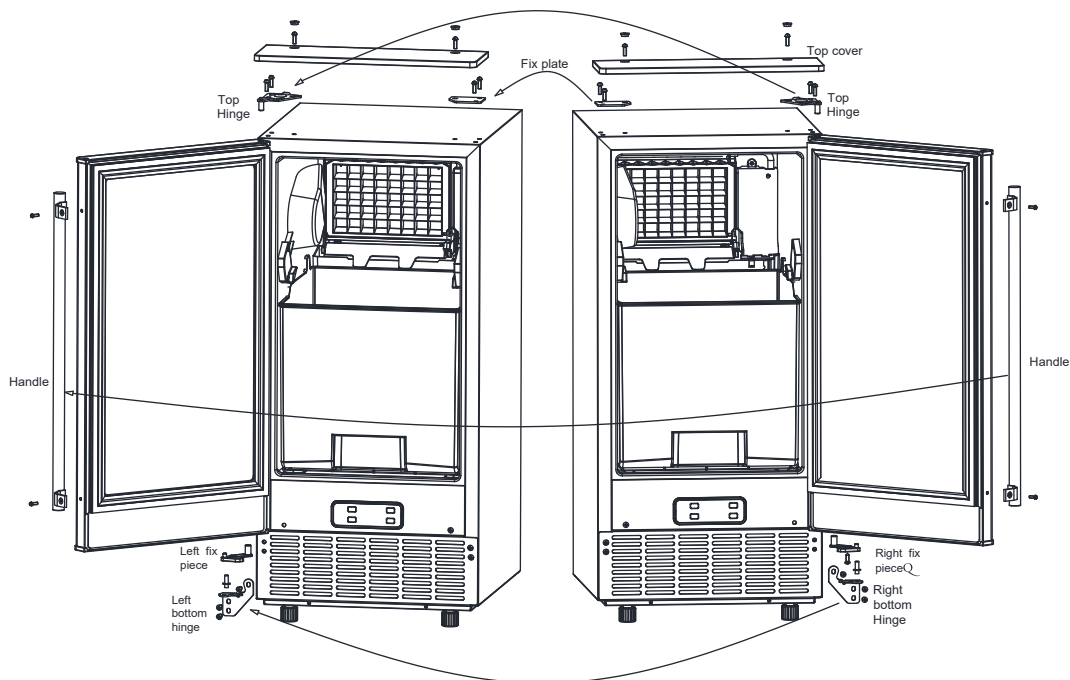

Operation Procedures

1. Ensure the unit is unplugged before starting door reversal.
2. Remove the 2 screw hole cover on the top cover, unscrew the two screws which is fixed to the top cover.
3. Remove the 2 screws from the top hinge, and 2 screws from the fix plate.
4. Lift the door up and take off the door.
5. Set the freezer door on a non-scratching surface with the outside up.
6. Release the 2 screws on the handle, fix on the opposite side of the door. Remove the screw on the right fix piece, fix the left fix piece (from accessory bag) to the door.

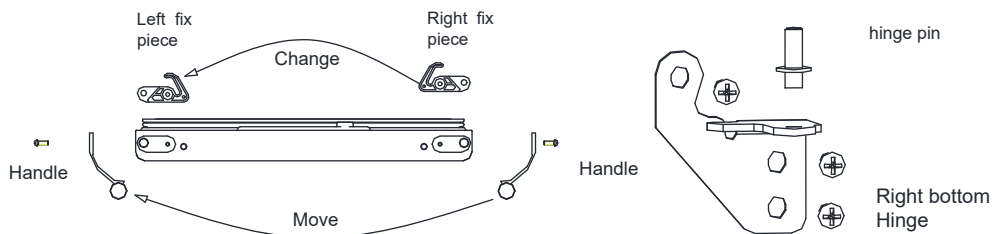

7. Remove the right bottom hinge by removing the 3 screws, then fix the 3 screws back without the hinge.
8. Remove the hinge pin on the right bottom hinge and reinstall on the left bottom hinge.
9. Remove the 3 screws from the left side and fix the left bottom hinge on the unit.
10. Place the door on the left bottom hinge. With the magnetic gasket holding the door in place, make sure the door is aligned with the unit, and secure the top hinge on the left with 2 screws.
11. Open and close the door several times to confirm the door is positioned correctly and the gasket is sealed well. If this is not the case, please adjust the door again.
12. Fix the fix plate back on the right side. Fix the top cover with 2 screws, cover the screw hole with the screw hole cover.
13. Wait at least 30 minutes before plugging in the refrigerator to allow the refrigerant to settle down. Then plug in the unit.

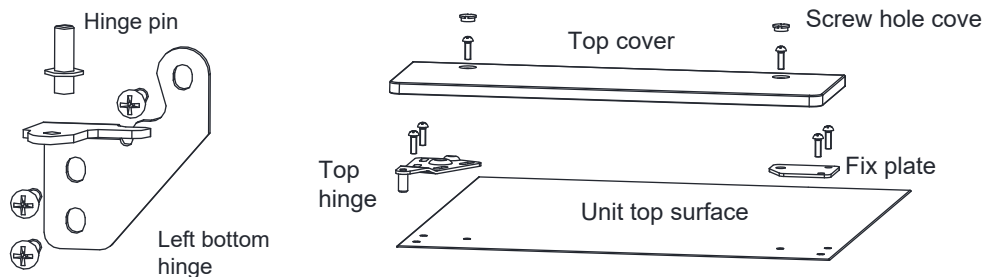

Operation Procedures

- a) This unit is not for outdoor use. Keep the proper room temperature and inlet water temperature according to above specification table. Otherwise it will affect the ice making performance.
- b) This unit should not be located near any heat source.
- c) The unit should be located on a firm & level foundation at normal counter top height.
- d) There must be at least a 2-inch clearance at the rear side for connection and a 10-inch clearance in the front to open the door and keep good air circulation.
- e) Do not put anything on the top of the ice maker.

Installation clearance

top view (mm)

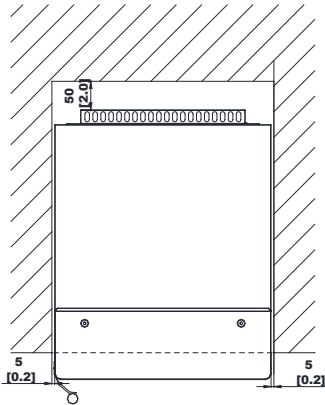

Side view (mm)

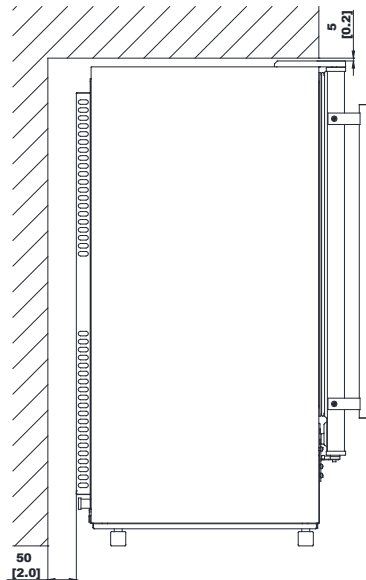

To ensure proper ventilation for your ice maker, the front of the unit must be completely unobstructed (at least a 16-inch free space). Allow about 0.2 inches clearance at rear, and 0.2 inches at top for proper air circulation. The installation should allow the ice maker to be pulled forward for servicing if necessary.

When installing the ice maker under a counter, follow the recommended spacing dimensions shown above. Place electrical and water supplies and drain fixtures in the recommended locations as shown.

Choose a well-ventilated area with temperatures above 50°F and below 90°F. This unit **MUST** be installed in an area protected from the elements, such as wind, rain, water spray, or drips. The ice maker requires a continuous water supply with 1–8 bar pressure as required in above specification table. The temperature of the water feeding into the ice maker should be between 41°F and 77°F for proper operation.

Operation Procedures

Drainage Pump Setting

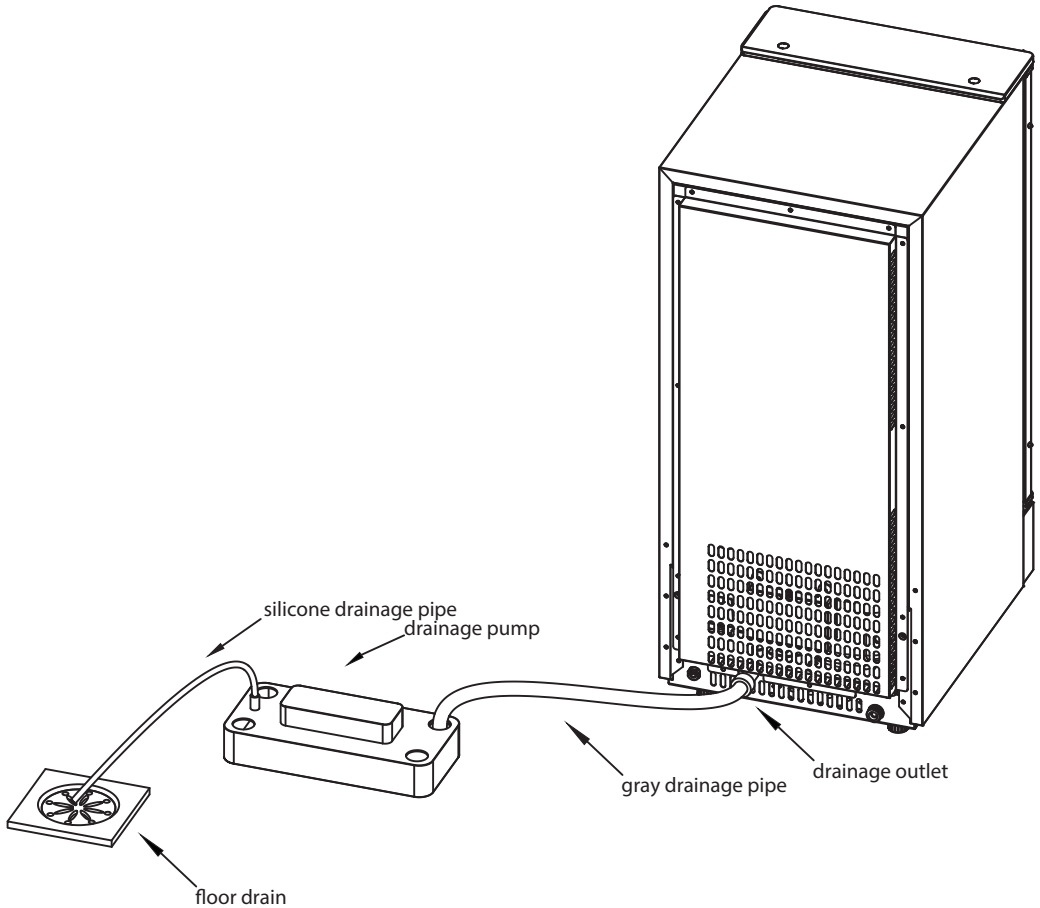

Operation Procedures

WARNING: THIS UNIT MUST BE EARTHED.

Electrical Shock Hazard

Plug into a grounding wall outlet.

Never remove the ground prong.

Use separate power supply or receptacle. Never use an adapter.

Never use an extension cord.

Failure to follow these instructions can result in death, fire, or electrical shock.

Before you move your ice maker into its final location, it is important to make sure you have the proper electrical connection.

It is recommended that a separate circuit, serving only your ice maker, be provided. Use receptacles that cannot be turned off by a switch or pull chain. If the supply cord or plug is to be replaced, it should be done by a qualified service engineer.

This appliance requires a standard 110–120Volt, 60Hz electrical outlet with good grounding means.

Recommended grounding method

For your personal safety, this appliance must be properly grounded. This appliance is equipped with a power supply cord having a grounding plug. To minimize possible shock hazard, the cord must be plugged into a mating grounding-type wall receptacle, grounded in accordance with the National Electrical Code and local codes and ordinances. If a mating wall receptacle is not available, it is the personal responsibility of the customer to have a properly grounding wall receptacle installed by a qualified electrician.

Cleaning your ice maker before first use

Before using your ice maker, it is strongly recommended to clean it thoroughly.

1. Open the ice getting door.
2. Clean with diluted detergent, warm water and a soft cloth.
3. Repeatedly clean the water contacting inner parts, you can pull the Water drain pipe of the water tank indicating "H" in above illustration to drain the cleaned water in the water tank, then next to clean inner ice-storing cabinet, till all of inner parts are cleanly, then drain out all of the cleaned water from the water drain port located at unit back indicating "7" in above illustration. And you must to reinstall back the water drain pipe of the water tank and the cap of the unit water drain port, otherwise, the unit will not make the ice normally. Suggest that you should discard the Ice cubes made by the first ice making cycle after cleaning.
4. The exterior of the ice maker should be cleaned regularly with a mild detergent solution and warm water.
5. Dry the interior and exterior with a clean soft cloth.

Operation Procedures

WATER CONNECTION FOR YOUR ICE MAKER

Important: Be sure to use the new hose-sets supplied with the appliance to connect to water mains and that old hose-sets should not be reused.

1. Connect the water supplying hose to the unit

Step 1: First remove the tape on the water inlet port for water supply (indicated in the following illustration "B") located at the back unit, then use your other hand's finger to press the out circle.

Step 2: Insert the one end of the white water hose into the water inlet port, and push inward completely, and install back the clipper, then water hose connection is completed.

2. Connecting the water drain pipe

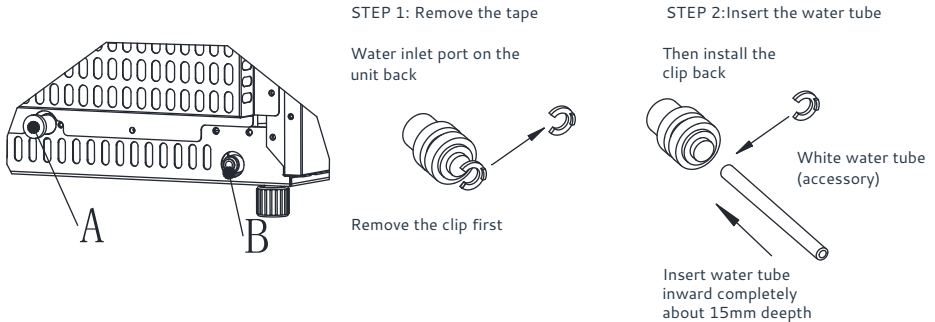

Pull out the water drainage cap with black color (indicated (A) in above illustration), then connect the white drainage pipe included in accessory, again connect the other end of this drainage to the main water drainage pipeline.

3. Connect the water hose to the water faucet of the water main supply system

First, install the supplied water quick-connector to the water faucet by screw thread; Second, remove the clipper from the water quick-connector, insert the other end of the water hose into this quick-connector port completely, then install back the clipper, this step is completed.

Note: The water faucet should be supplied by the customer himself.

Important: The water pressure of main water supply system must be at least 0.04–0.6 MPa.

Operation Procedures

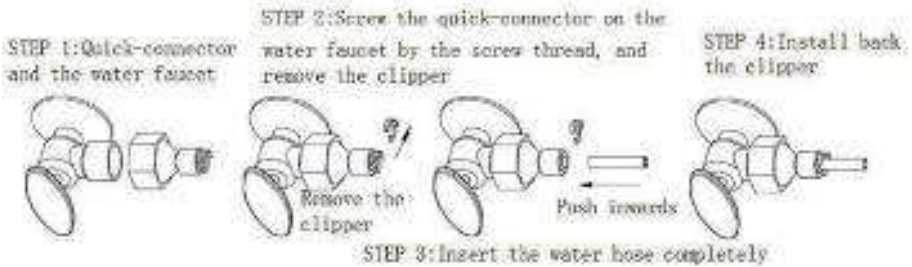

Operation-button and display-area diagram



OPERATION OF ICE MAKING PROCESS

1. Start up: Plug in the power plug, and the symbol will flash in the display window. Press the ON/OFF button on the control panel. The machine will start to make ice when the external pipe adds water to reach the standard level on the water tank through the electromagnetic water valve. Thereafter, the symbol will remain bright constantly in display window and symbol will rotate. The ambient temperature will be displayed on the upper left of the display window. "80°F" means the ambient temperature is 80°F. Several minutes later, the flashing numbers will be displayed in the ambient temperature display area, and the flashing number "10M" means the unit still needs 10 minutes to finish this ice making cycle.

2. When the ice making cycle finishes, the unit enters deicing process, and the symbol flashes. Next, the external pipe adds water to the water tank through the electromagnetic valve, and the arrow on the symbol will flash until the water reaches the standard level. Finally, the symbol extinguishes, and the unit enters the next ice making cycle. When the water cannot reach the standard level, the symbol is always bright, and the unit stops working. Restart the unit if there is a shortage of water; otherwise it will start up automatically after 15 minutes.

Note: Each ice making cycle lasts between 11 and 20 minutes. The ice making time varies according to the changes of ambient temperature and the water temperature, especially in the first ice making cycle. The ice making cycle will be longer because of the high water temperature in the water tank, but it will not exceed 30 minutes.

3. Adjust the ice thickness: Press the "+" and "-" button on the control panel to adjust the ice thickness. The number in the bottom left of the display window is the setting of the ice making time, and the default setting is "0". To produce thicker ice, add one minute of ice making time by pressing "+" button once; in contrast, to produce thinner ice, reduce one minute of ice making time by pressing "-" once. Restart the machine and it will go back to the default setting of "0".

Note: The time currently set only changes the next and the subsequent ice making cycles.

Operation Procedures

4. When the  symbol lights up, the machine stops working, and it will work again after you take out the ice.

5. Shut down the unit: During the ice making process, press the "ON/OFF" button on the control panel to shut down the unit and the unit enters the standby mode. If you press "ON/OFF" longer than 5 seconds during ice making process, then the unit enters the deicing process directly. This function can help remove the ice on the ice plate. Press "ON/OFF" to shut down the machine.

6. Timing setting: Setting range: 1-24 hours

Time shutdown: When the unit is running, it can set up the timing shutdown. Time on: When the unit is on standby, you can set the unit with ON-TIMER.

How to set up the timing

Press the TIMER button, the default timing time is "1H" in display window, then press "+" button to adjust the timing time you need, every time you press the "+" button, the time add 1 hour; press "-" button can reduce the timing time. During the process of time adjustment, the "H" in the lower corner of the number will flash, then after 5 seconds flashing without pressing, the "H" letter will change from flashing to always displaying, meaning the timer program has been completed.

In standby condition display "5H", means the unit will start automatically after 5 hours; In ice making condition display "5H", means the machine will shut down automatically after 5 hours, the "H" in the display screen indicates that the machine currently has a timing function, and the number in front will be smaller and smaller. Until it becomes zero, the timing ends, and the machine enters the mode you need.

How to cancel timing

When the unit has a timing (the display window will display XX H), press "TIMER" button, the timing is canceled after the number on the screen and "H" are extinguished.

When the unit has a timing, the display area in the lower left corner will display the timing time and the ice making setting time, and the display content will be switched every 5 seconds.

7. Automatic self-cleaning program, the default cleaning time is 20 minutes.

Start the self-cleaning program:

After connecting all of the water pipe, plug on the main power supply plug, then press "TIMER CLEAN" button on control panel for more than 5 seconds, to enter the self-cleaning program, the symbol  will rotate on display screens, time count down area will display 20M. The "CLEAN" light will always be on during this period, the digit window will indicate the time remaining, the water pump runs for 8 minutes and stops for 3 minutes, and will always recycle. The total duration time is 20 minutes for one self-cleaning program. Also when the water pump stops, the water will supply to the water tank automatically.

Cancel the self-cleaning program: It takes about 20 minutes to complete one self-cleaning program. When the program is over, the system will be in off-state automatically. You can also press the "ON/OFF" button on control panel to cancel the self-cleaning program by force.

8. How to switch Fahrenheit(°F) to Celsius(°C)?

Press "+" or "-" button longer than 5 seconds, it will automatically switch.

Wiring Diagram

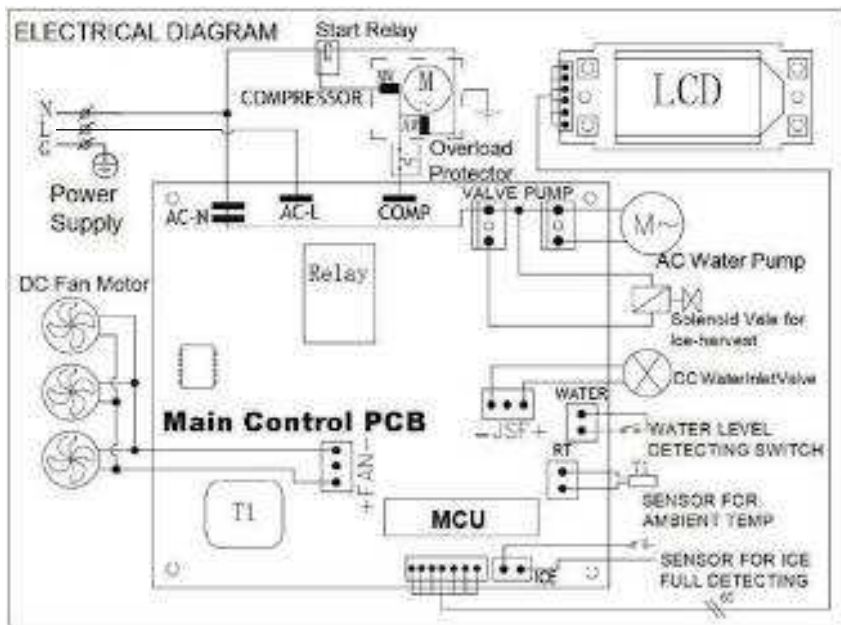

Normal Sounds

Your new ice maker may make sounds that are not familiar to you. Most of the new sounds are normal. Hard surfaces like the floor, walls and cabinets can make the sounds seem louder than they actually are. The following describes the kinds of sounds that might be new to you and what may be making them.

- You will hear a swooshing sound when the water valve opens to fill the water tank for each cycle.
- Rattling noises may come from the flow of the refrigerant or the water line. Items stored on top of the ice maker can also make noises.
- The high-efficiency compressor may make a pulsating or high-pitched sound.
- Water running from the water tank to the evaporator plate may make a splashing sound.
Water running from the evaporator to the water tank may make a splashing sound.
- As each cycle ends, you may hear a gurgling sound due to the refrigerant flowing in your icemaker.
- You may hear air being forced over the condenser by the condenser fan. During the harvest cycle, you may hear the sound of ice cubes falling into the ice storage bin.
- When you first start the ice maker, you may hear water running continuously. The ice maker is programmed to run a rinse cycle before it begins to make ice.

I Wiring Diagram

Preparing the Ice Maker for Long Storage

If the ice maker will not be used for a long time, or is to be moved to another place, it will be necessary to drain out all of the water in the system.

1. Allow all of the ice cubes to be ejected from the evaporator of ice maker.
2. Turn off the unit, and unplug the power cord.
3. Shut off the water supply at the main water supply.
4. Disconnect the water supply hose from the water inlet valve.
5. Pull out the water drain pipe of the water tank indicating "H" in above illustration to drain out the water in the water tank. When all of the water has been drained out, to reinstall back the water drain pipe of the water tank.
6. Then drain out all of the water from the water drain port located at unit back indicating "7" in above illustration.
7. Disconnect the water drain pipe to the main drain pipeline or floor drain, plug on the drain cap again.
8. Drop the door open to allow for circulation and to prevent mold and mildew.
9. Leave water supply hose and power cord disconnected until ready to reuse.
10. Dry the interior & wipe the outside of the unit.
11. Put a plastic bag on the unit to resist out dust & dirt.

Cleaning And Maintenance



WARNING:

Before carrying out any cleaning or maintenance operations, unplug the ice maker from the main power supply. (EXCEPTION: Ice maker self-cleaning program).

Do not use any alcohol or fume for cleaning/sanitization of the ice maker. It may cause cracks on the plastic parts.

Ask a trained service person to check and clean the condenser at least once a year, in order to let the unit work properly.

This appliance must be cleaned by use of a water jet.

CAUTION

If the ice maker has been left unused for a long time, before the next use, it must be thoroughly cleaned. Follow carefully any instructions provided for cleaning or use of sanitizing solution. Do not leave any solution inside the ice maker after cleaning.

Periodic cleaning and proper maintenance will ensure efficiency, top performance, hygienic, and longer life of unit. The maintenance intervals listed are based on normal conditions. You may want to shorten the intervals if you have pets, or the unit is used outdoors, or there are other special considerations.

What shouldn't be done

Never keep anything in the ice storage bin that is not ice: objects like wine and beer bottles are not only unsanitary, but also it's labels may slip off and obstruct the drain pipe.

Exterior Cleaning

The door and cabinet may be cleaned with a mild detergent and warm water solution such as 28g of dish washing liquid mixed with 7.5L of warm water. Do not use solvent-based or abrasive cleaners. Use a soft sponge and rinse with clean water. Wipe with a soft clean towel to prevent water spotting.

Stainless steel models can discolor when exposed to chlorine gas and should be cleaned. Clean stainless steel models with a mild detergent and warm water solution and a damp cloth.

Never use abrasive cleaning agents.

NOTICE:

Stainless steel models exposed to chlorine gas and moisture, such as in areas with spas or swimming pools, may have some discoloration of stainless steel. Discoloration from chlorine gas is normal.

Interior Cleaning

For Ice Storage Bin

The ice storage bin should be sanitized occasionally. Clean the bin before the ice maker is used for the first time and reused after stopping for an extended period of time. It is usually convenient to sanitize the bin after the ice making system has been cleaned, and the storage bin is empty.

1. Disconnect power to the unit.
2. Open the door and with a clean cloth, wipe down the interior with a sanitizing solution made of 28g of household bleach or chlorine and 7.5L of hot water (95°F to 115°F).
3. Rinse thoroughly with clear water. The waste water will be drained out through the drain pipe.
4. Reconnect power to the unit.

The ice scoop should be washed regularly. Wash it just like any other food container.

Cleaning And Maintenance

WARNING

DO NOT use solvent cleaning agents or abrasives on the interior. These cleaners may transmit taste to the ice cubes, or damage or discolor the interior.

Ice Making Parts Cleaning

During the use of your unit, periodically clean the main system of your ice-maker.

- 1、 Repeat above step to clean the water tank and other inner parts of the unit.
- 2、 Especially, to the water dividing pipe on the evaporator, when the compressor and the water pump run normally, but if there is no water flowing out from the water dividing pipe or the water flow is very small, please discharge this water dividing pipe to clean carefully. Clean each little hole on the water dividing pipe displayed in the following illustration, make sure each hole is not clogged by anything, then install back to the original location.
- 3、 When there are ice cubes on the surface of the evaporator, but can't fall down easily, do not use the mechanical substance to remove it by force; Only press the "ON/OFF" button for more than 5 seconds, the unit will enter the ice melting process, after some while, the big ice cubes will fall down, then turn off the unit and unplug the power cord to clean the surface of the evaporator.

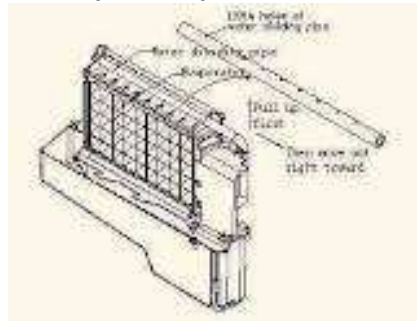

- 4、 For the water tank and ice-full detecting plate Also the water tank and the ice-full detecting plate is very important to keep your ice cubes hygienic. Put a mixture of neutral cleaner & water into a clean water jet, then spray onto all the inner surface of tank & the ice detecting plate. Wipe these surfaces as far as possible with a clean cloth. Then, spray the surfaces with clean water, wiping with a dry clean cloth. Then drain out the cleaned water in the water tank by pulling out the water drain pipe of the water tank indicating "H" in above illustration. When all of the clean water has been drained out, reinstall back the water drain pipe of the water tank. Suggestion: After cleaning the interior parts, install back to its respective position, and return machine to work, discard first batch of ice.

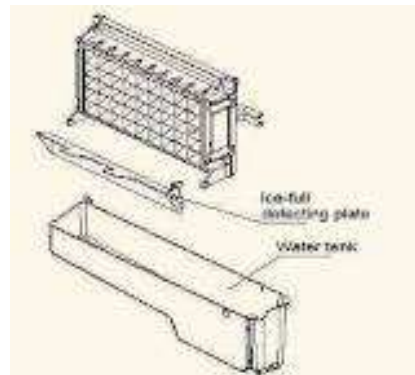

Cleaning And Maintenance

Ice Making Assembly System Cleaning by Using Nu-Calgon Nickel Safe Ice-machine Cleaner

Minerals that are removed from water during the freezing cycle will eventually form a hard scaly deposit in the water system. Cleaning the system regularly helps remove the mineral scale buildup. How often you need to clean the system depends upon how hard your water is. With hard water of 4 to 5 grains/liter, you may need to clean the system as often as every 6 months.

1. Turn off the ice maker. Keep the ice maker connected to the water supply and drainpipe. But shut off the water faucet of main water supply.

2. Open the door and scoop out all of the ice cubes. Either discard them or save them in an ice chest or cooler.

3. Making the cleaning solution. Please mix the Nu-Calgon Nickel Safe Ice Machine Cleaner with water to make the cleaning solution.

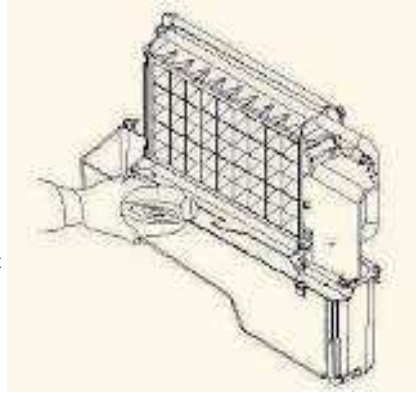

WARNING

Wear rubber gloves and safety goggles (and/or face shield) when handling Ice Machine Cleaner or sanitizer.

Use a plastic or stainless container with more than 4 liters capacity, mix 300 ml Nu-Calgon Nickel Safe Ice-machine Cleaner with 2.8 liters of warm water about 120°F -140°F. Then divide them for 2 shares equally in 2 cups. It is better to keep the temperature of each cup of the cleaning solution.

4. Check and be sure that the water drain pipe of the water tank has been installed properly in the slot of the tank wall. Then pour one cup of Nickel-Safe Ice Maker Cleaning Solution into the water tank. Wait for around 5 minutes.

5. Turn on the power to the ice maker, then press "TIMER CLEAN" button on the control panel for more than 5 seconds, to enter the self-cleaning program. Same as above explanation, the water pump runs for 8 minutes and stops for 3 minutes, one cycle, and again another cycle. The total duration time is 30 minutes for one self-cleaning program.

During this process, the "CLEAN" light will always be on during this period, and the digit window will indicate the remaining time.

6. After 30 minutes of one self-cleaning program is complete, pull out the drain pipe of the water tank, drain the cleaning solution down to the lower ice storage bin. Shake the unit slightly to drain out all of the cleaning solution completely. Then install back the drain pipe to the slot of the water tank.

7. Repeat steps 4--6 to clean the ice making assembly system again.

Cleaning And Maintenance

WARNING

The ice machine cleaner contains acids.
DO NOT use or mix with any other solvent-based cleaner products.
Use rubber gloves to protect hands. Carefully read the material safety instructions on the container of the ice machine cleaner.

8. Then open the water faucet of the main water supply, Let the water flow in the unit. Again press the "TIMER CLEAN" button on control panel for more than 5 seconds, to enter the self-cleaning program. Same as above explanation, the water pump runs for 8 minutes and stops for 3 minutes, one cycle, and again another cycle. The total duration time is 30 minutes for one self-cleaning program.

During this process, the "CLEAN" light will always be on during this period, and the digit window will indicate the time remaining. Through this process, It will rinse the water dividing pipe, evaporator, water pump, silicone pipe, and water tank etc.

9. After one self-cleaning program is complete, pull out the drain pipe of the water tank, drain the cleaning solution down to the lower ice storage bin, also shake the unit slightly to drain out all of the water completely. Then install back the drain pipe to the water tank slot tightly.

10. Repeat the steps 8-9 again for 2 times.

11. Following the above program to clean the ice storage bin.

12. Then this special cleaning program is finished, you can return to the regular ice making mode. Suggest to discard the first batch of ice cubes.

Cleaning Suggestions

1) DAILY CLEANING

The ice shovel, door and the water dividing pipe should be cleaned by yourself per each day. At the end of every day, rinse the ice shovel and wipe the both sides of the door with a clean cloth.



2) SEMI-MONTHLY CLEANING

The ice shovel, ice bin, water tank, the ice-full detecting plate and the surface of the evaporator are to be cleaned by yourself semi-monthly according to interior cleaning program.

3) SEMI-ANNUAL CLEANING

All the components & surfaces exposed to water or ice cubes, like ice storage bin, water tank, door, evaporator, water pump, silicone tube, water dividing pipe, etc. should be cleaned **by Using Nu-Calgon Nickel Safe Ice-machine Cleaner** per each 6 months. They should be cleaned by the serviceman according to ice making assembly system cleaning program.

I Troubleshooting

PROBLEM	POSSIBLE CAUSE	SOLUTION
 "indicator is on.	<ul style="list-style-type: none"> No water supply 	<ul style="list-style-type: none"> Check the main water supply pressure or check the water supply hose is blocked or not, adding the water pressure or cleaning the hose necessary.
	<ul style="list-style-type: none"> Floating ball of the water level detecting switch is blocked, can't be raised up. 	<ul style="list-style-type: none"> Clean the water tank and the water level detecting switch.
	<ul style="list-style-type: none"> Water flows out from the water Tank. 	<ul style="list-style-type: none"> Place the unit on the level position, not on the slope.
	<ul style="list-style-type: none"> Water flows out from the water drain pipe of the water tank. 	<ul style="list-style-type: none"> Pull out the pipe and install back to the slot of the water tank properly.
The unit start to enter the ice making process, but no water flowing in the unit, andThe  "indicator flashes	<ul style="list-style-type: none"> Water-supply hose has broken down or water flows in very slowly. 	<ul style="list-style-type: none"> Check the main water supply pressure or check to see if the water supply hose is blocked or not, adding the water pressure or cleaning the hose necessary.
Water pump is working, but no water flows out from the water dividing pipe	<ul style="list-style-type: none"> The little holes on the water dividing pipe is blocked. 	<ul style="list-style-type: none"> Clean these little holes.
The transparency of the ice cube is not very good	<ul style="list-style-type: none"> Water quality is bad 	<ul style="list-style-type: none"> Change the water supply, or use the water filter to soften or filter the water.
The ice cube shape is irregular	<ul style="list-style-type: none"> Water quality is not good or the water tank is very dirty. 	<ul style="list-style-type: none"> Clean the water tank, and change with new water.
	<ul style="list-style-type: none"> The little holes on the water dividing pipe are blocked. 	<ul style="list-style-type: none"> Clean the water dividing pipe,make sure all nine holes are unclogged.
The ice cube is very thin	<ul style="list-style-type: none"> Ambient temperature is too High. 	<ul style="list-style-type: none"> Move the unit to a low temperature space, or lengthen the time of each ice making cycle.
	<ul style="list-style-type: none"> Air circulation around the unit is not good. 	<ul style="list-style-type: none"> Make sure there is more than 20CM space between the unit back & front and the obstacle.
Ice cube is too thick	<ul style="list-style-type: none"> Ambient temperature is too low 	<ul style="list-style-type: none"> Reduce the time of each ice making cycle.
 "indicator is on.	<ul style="list-style-type: none"> The ice storage bin is full of ice cubes. 	<ul style="list-style-type: none"> Take out some ice cubes.
Ice making cycle is normal, but there is no ice cubes produced	<ul style="list-style-type: none"> The temperature of ambient, or water in water tank is too high. 	<ul style="list-style-type: none"> Move unit to a place with temperature lower than 90 °F and change to the low temperature water.
	<ul style="list-style-type: none"> Refrigerant leakage. 	<ul style="list-style-type: none"> Please contact support@euhomy.com
	<ul style="list-style-type: none"> Cooling system tube is clogged. 	<ul style="list-style-type: none"> Please contact support@euhomy.com

| Error Indicator

- a) Ambient temperature sensor breakdown Display E1 in digital window.
- b) The machine not make ice or the gas leak Display E2 in digital window
- c) Magnetic control switch cutoff---- "Full" light will be on when plugging on or just turning on the unit. It will delete the breakdown display if this switch is electric shorted.
- d) During the ice making process, press the "ON/OFF" button for more than 5 seconds, the unit will start to enter the ice harvest program. After the ice harvest program, it will continue to enter the ice making process.

Correct Disposal Of This Product



This marking indicates that this product should not be disposed with other household wastes throughout the EU. To prevent possible harm to the environment or human health from uncontrolled waste disposal, recycle it responsibly to promote the sustainable reuse of material resources. To return your used device, please use the return and collection systems or contact the retailer where the product was purchased. They can take this product for environmental safe recycling.

Warranty

Euhomy offers a limited 1-year warranty ("warranty period") on all of our products purchased new and unused from Euhomy company, with an original proof of purchase and where a defect has arisen, wholly or substantially, as a result of faulty manufacture, parts or workmanship during the warranty period. The warranty does not apply where damage is caused by other factors, including without limitation:

- (a) normal wear and tear;
- (b) abuse, mishandling, accident, or failure to follow operating instructions;
- (c) exposure to liquid or infiltration of foreign particles;
- (d) servicing or modifications of the product other than by Euhomy;
- (e) commercial or non-household use.

The Euhomy warranty covers all costs related to restoring the proven defective product through repair or replacement of any defective part and necessary labor so that it conforms to its original specifications. A replacement product may be provided instead of repairing a defective product. Euhomy's exclusive obligation under this warranty is limited to such repair or replacement. A receipt indicating the purchase date is required for any claim, so please keep all receipts in a safe place. Although greatly appreciated, the product registration is not required to activate any warranty and product registration does not eliminate the need for the original proof of purchase. The warranty becomes void if attempts at repair are made by non-authorized third parties and/or if spare parts, other than those provided by Euhomy, are used.

You may also arrange for service after the warranty expires at an additional cost. These are our general terms for warranty service, but we always urge our customers to reach out to us with any issue, regardless of warranty terms. If you have an issue with a Euhomy product, please contact us (support@euhomy.com), and we will do our best to resolve it for you.

Option 1

1. Search for "QR Code" on Facebook.
2. Scan the attached QR Code.
3. Become a member of the group.
4. Activate your warranty in the pinned post.



Option 2

1. Open your phone build-in Camera.
2. Point it to the attached QR Code. Make sure you can see all four corners of the QR code in the camera.
3. Tap the pop-up banner and go to the Active Your Warranty link.
4. Become a member of the group, and your warranty is now active



EUHOMY

Live the *cool life*



Email: support@euhomy.com



Facebook: [@Euhomy.Official](https://www.facebook.com/Euhomy.Official)